

C:\WINDOWS\DESKTOP\PROJECTS\MC CALL FOUNDATION PROJECTS\883 MAIN STREET FOUNDATION PROJECTS\ROOF DETAILS.DWG 5/31/24 8:38 AM

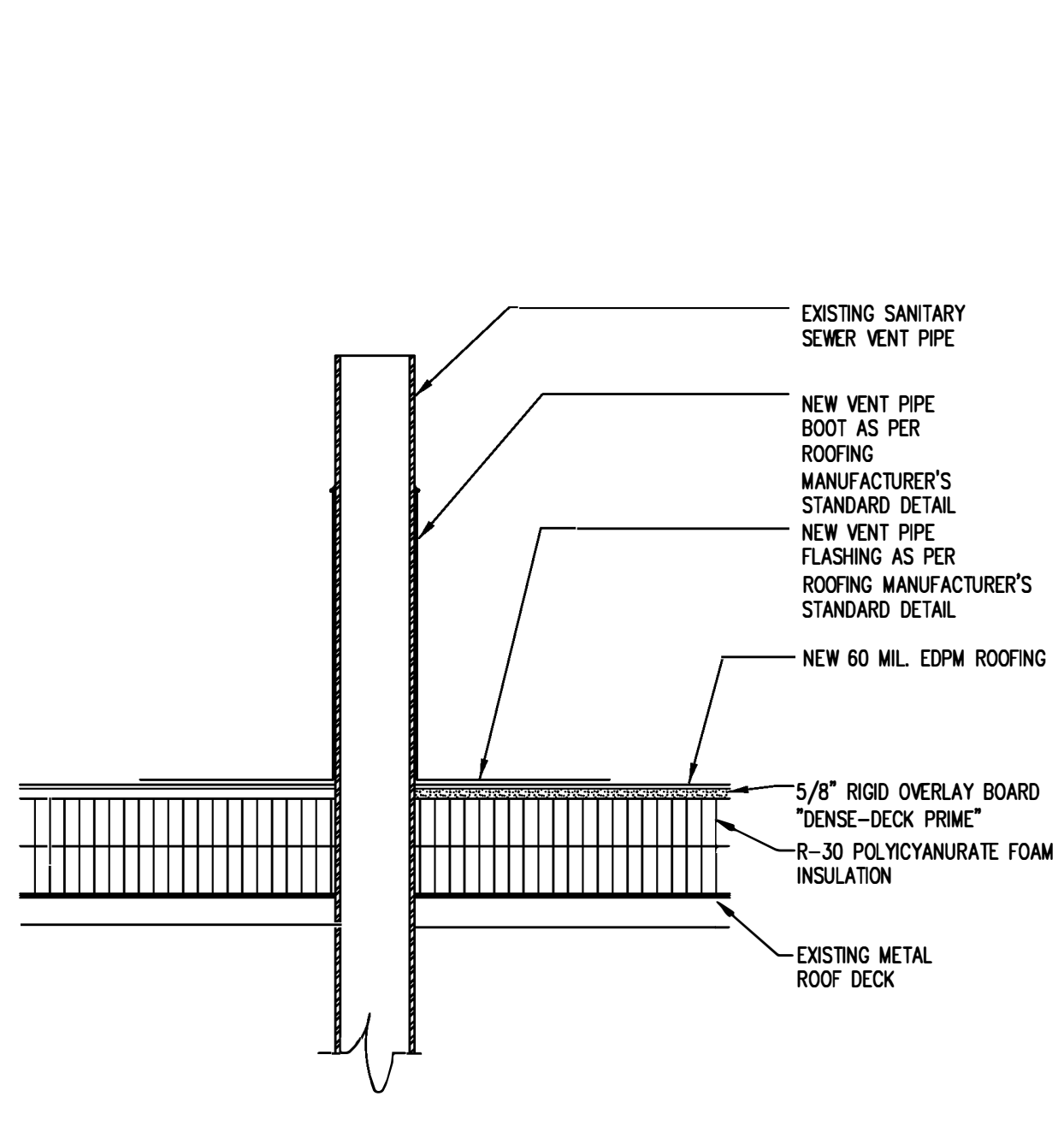

1 SANITARY SEWER VENT DETAIL  
A2 1.5"=1'-0"

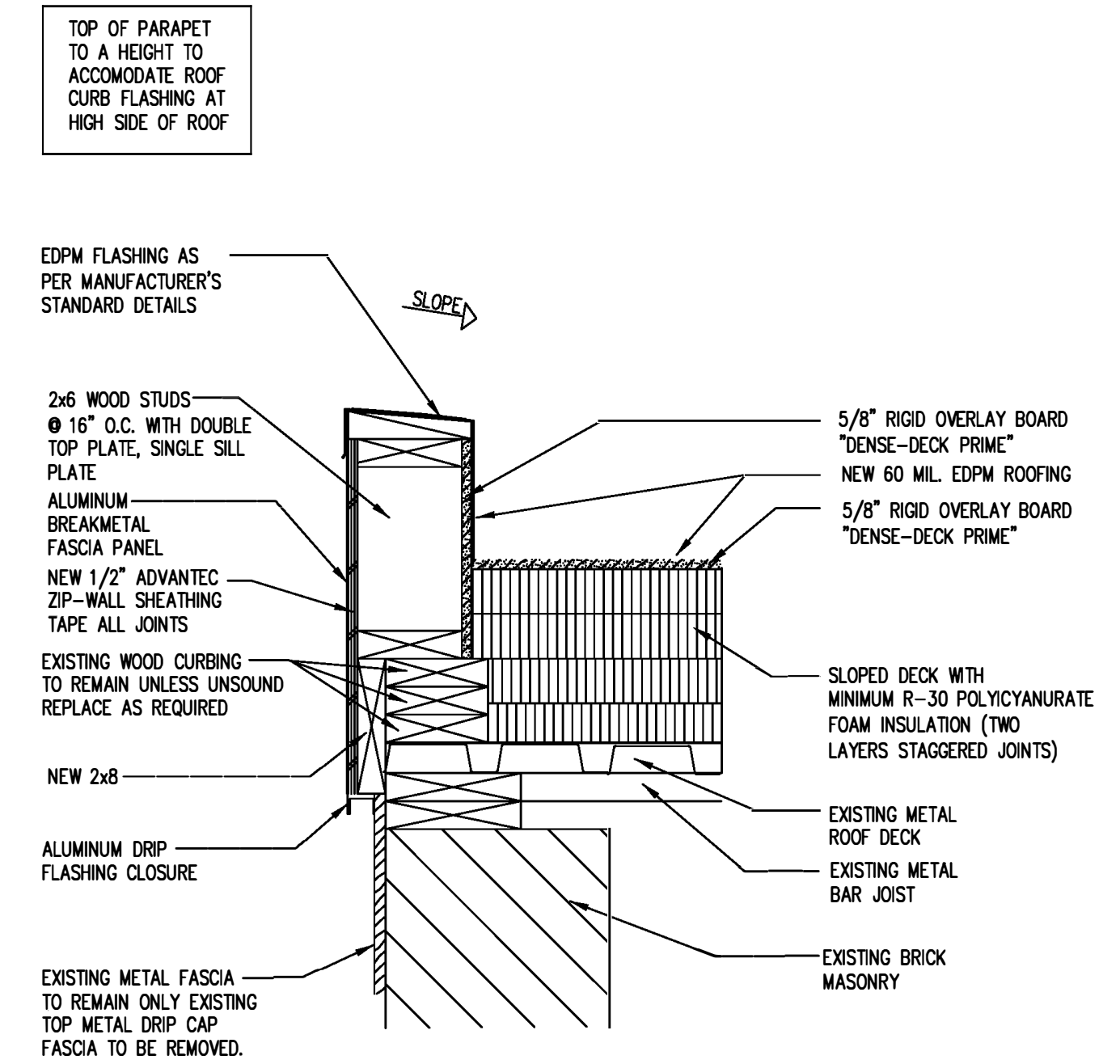

2 NON BEARING WALL CAP DETAIL  
A2 1.5"=1'-0"

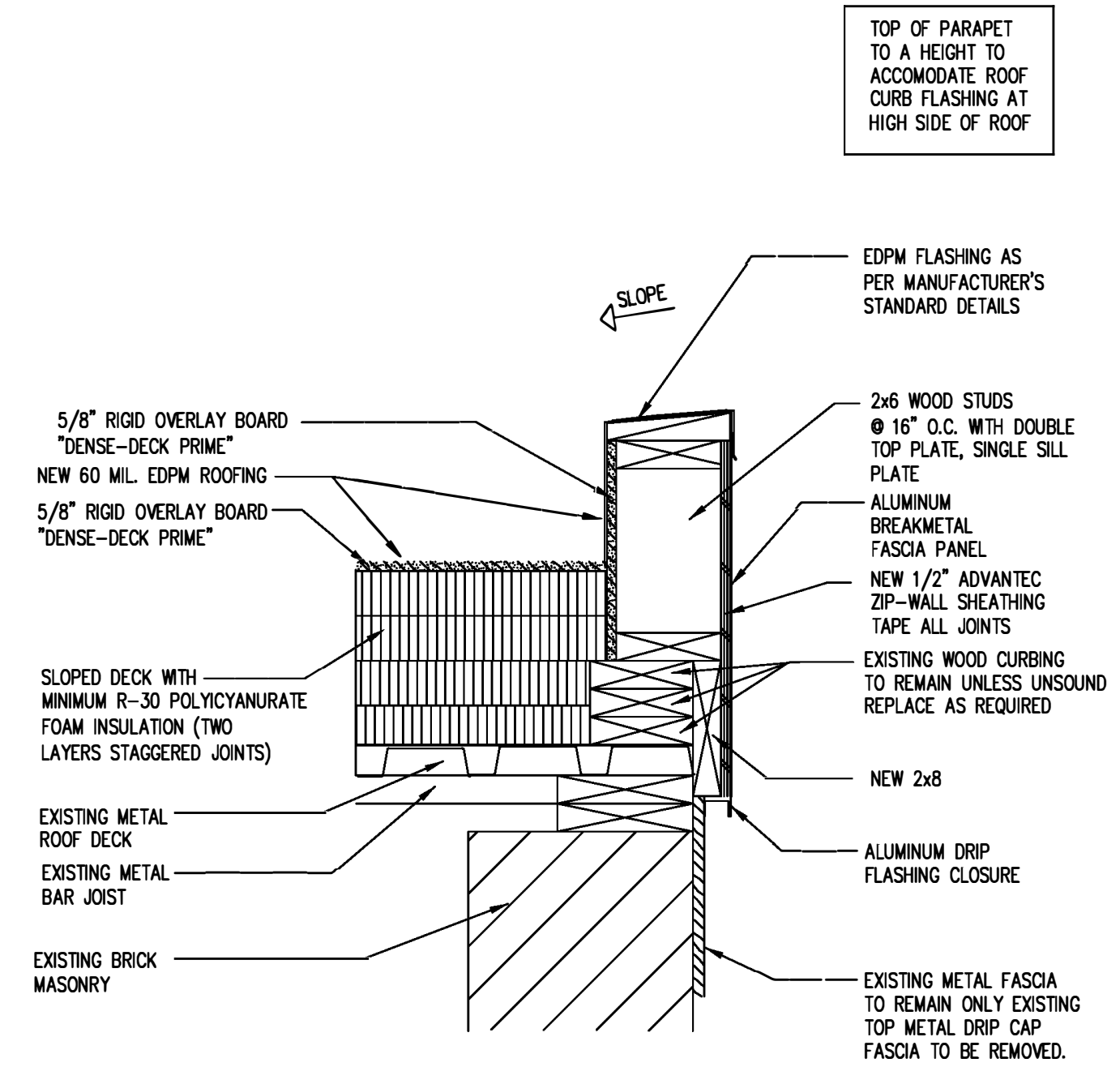

3 NON BEARING WALL CAP DETAIL  
A2 1.5"=1'-0"

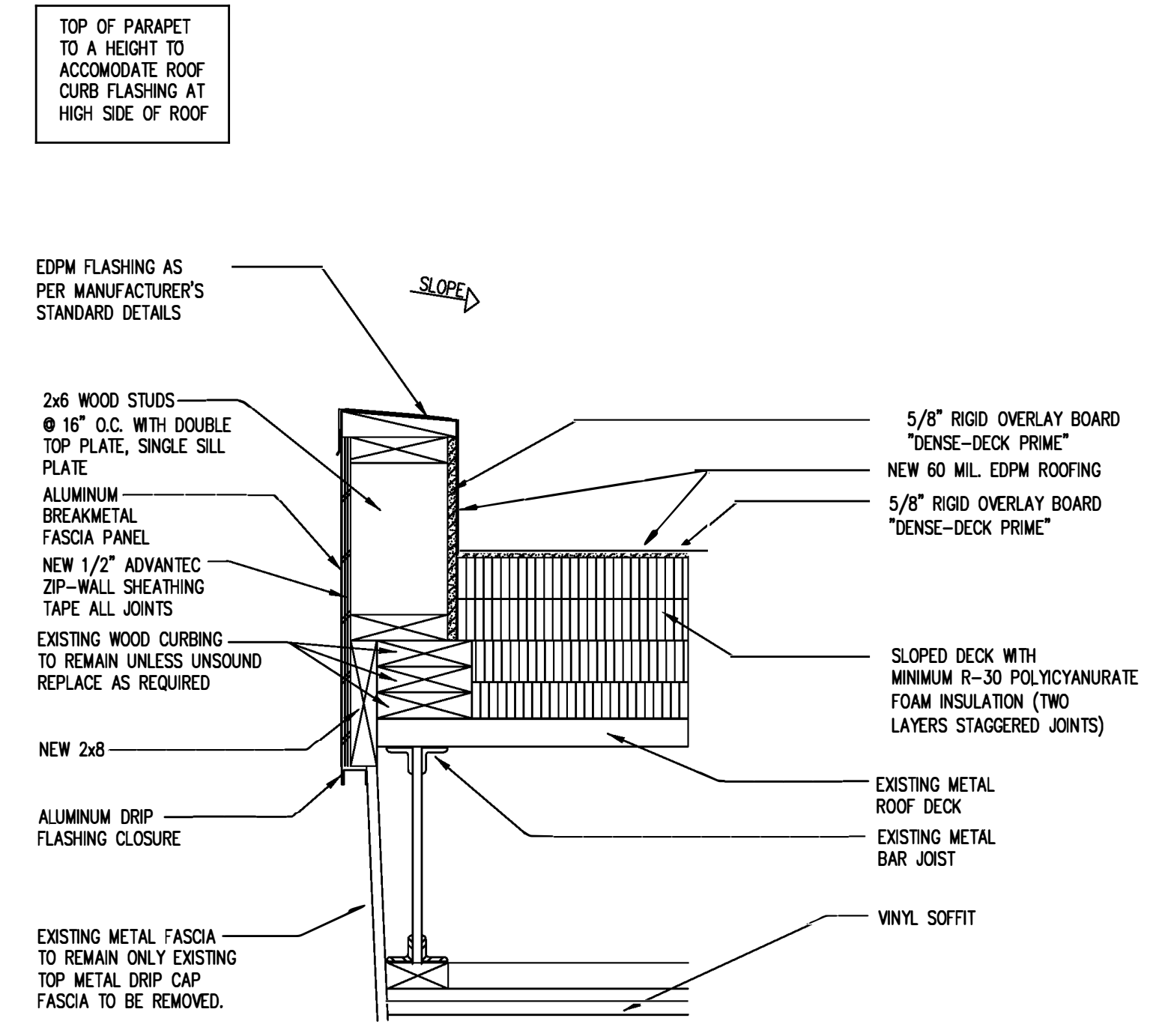

4 WALL CAP DETAIL  
A2 1.5"=1'-0"

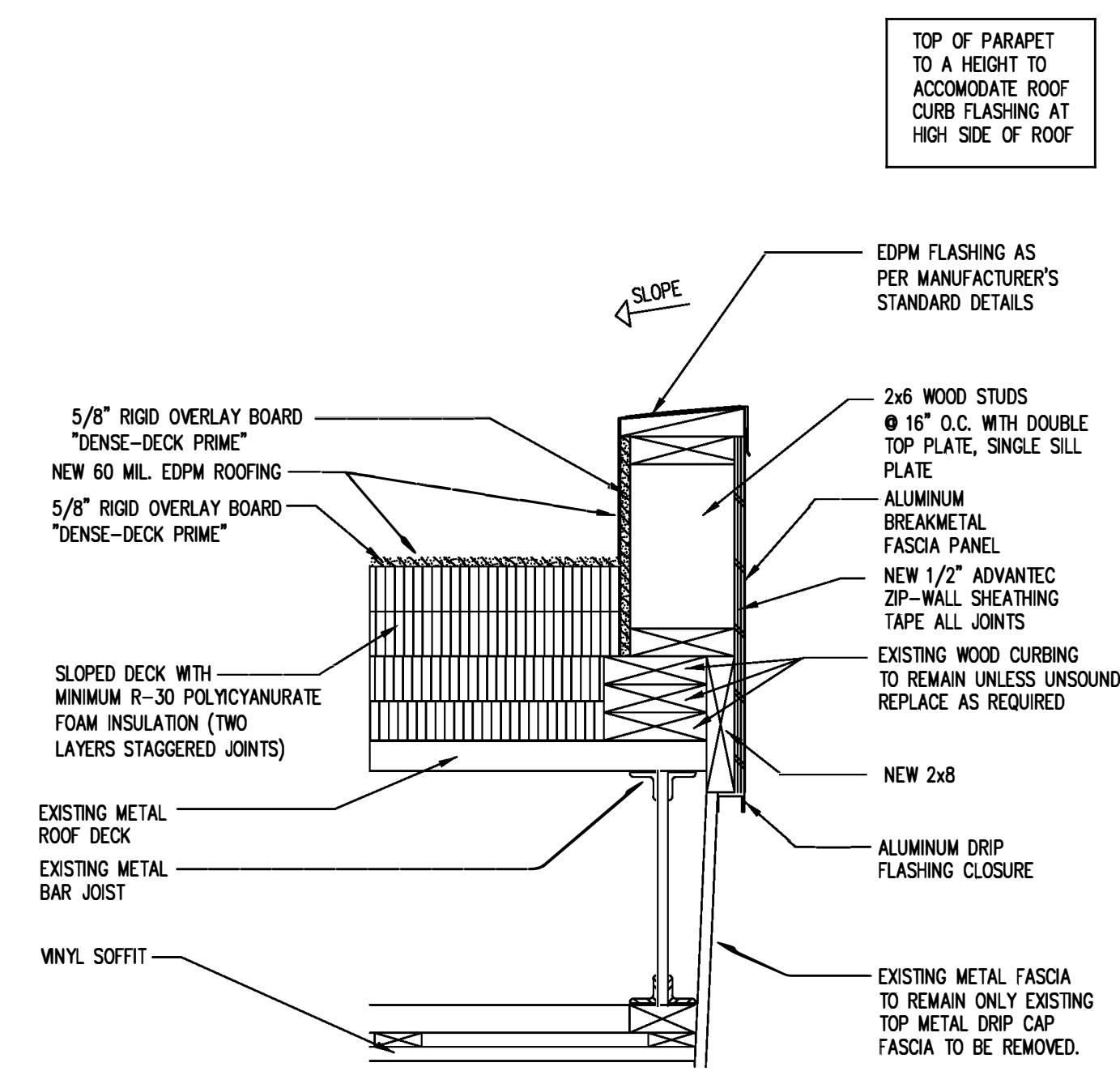

5 WALL CAP DETAIL  
A2 1.5"=1'-0"

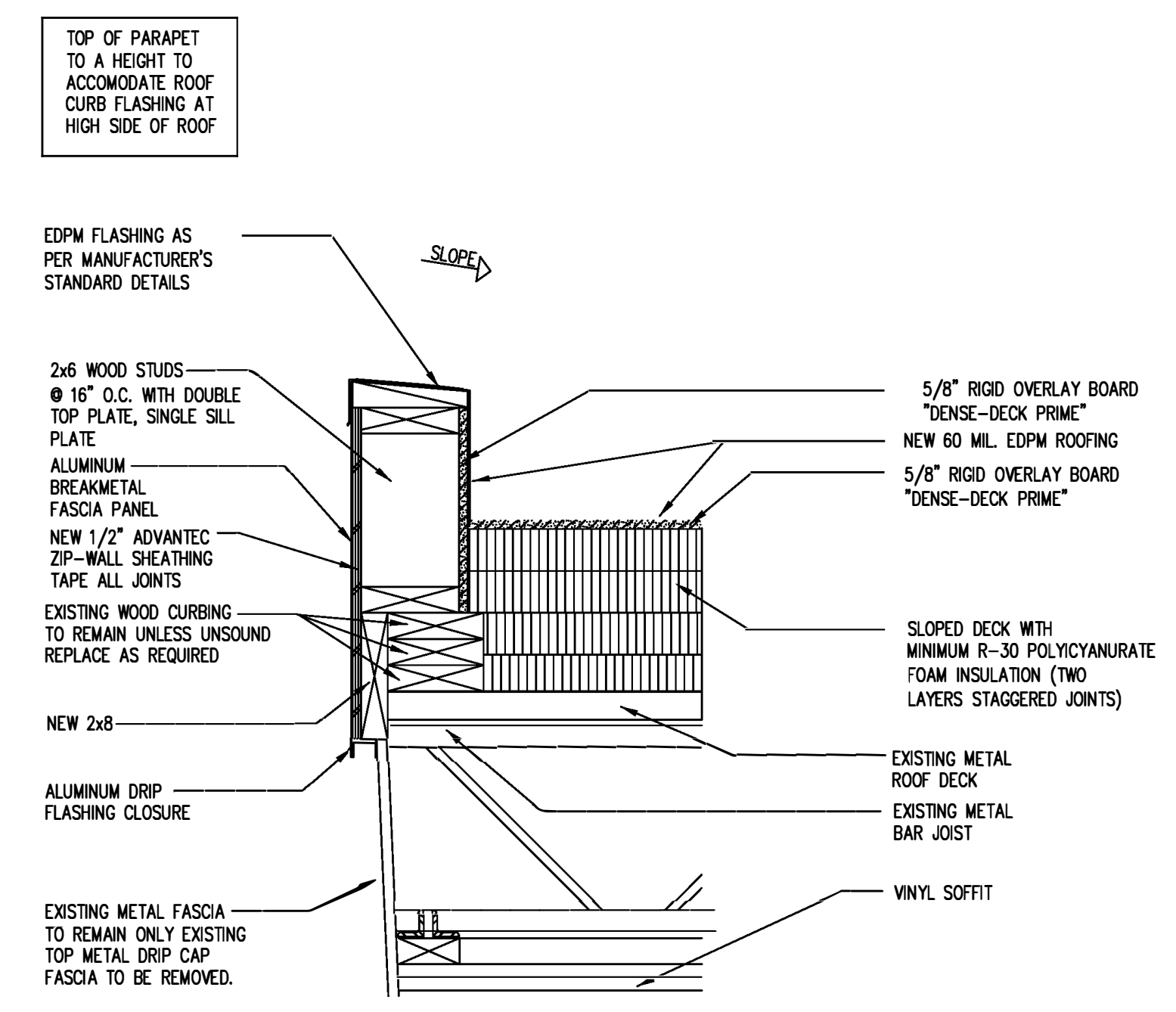

6 WALL CAP DETAIL  
A2 1.5"=1'-0"

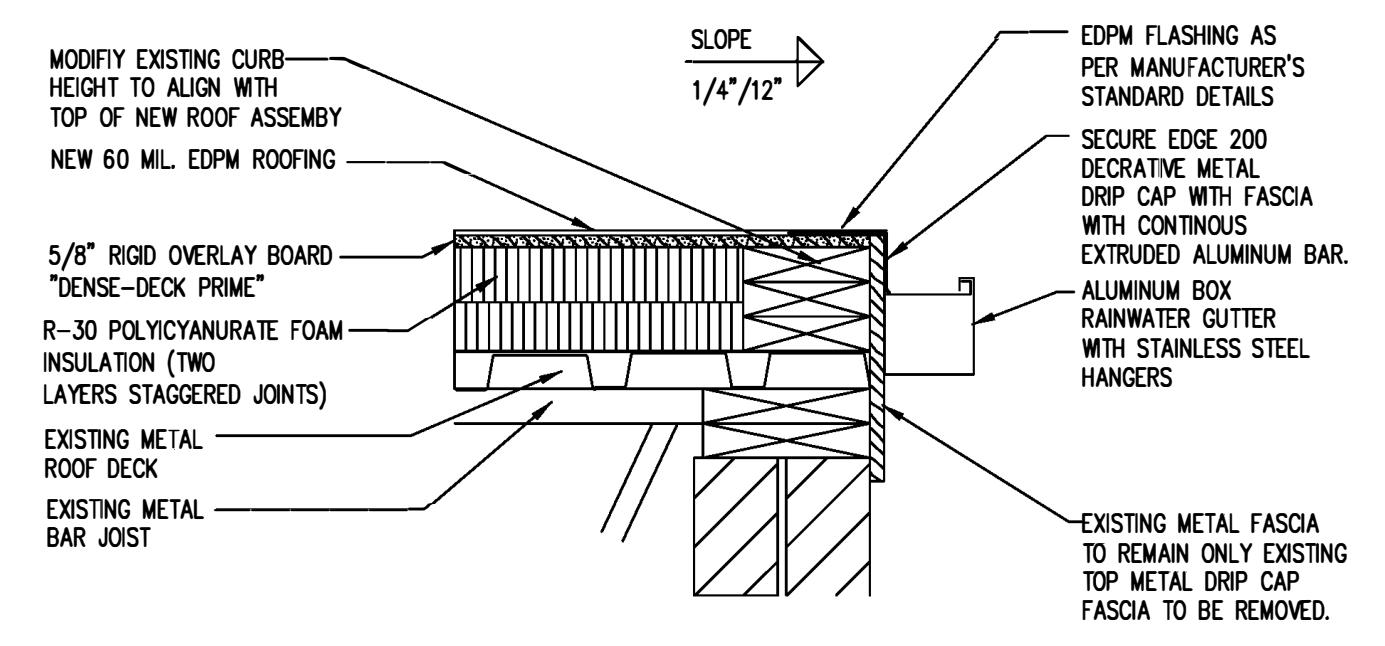

7 BEARING WALL ROOF CAP FLASHING WITH ROOF RAINWATER GUTTER  
A2 1.5"=1'-0"

ROOF REPLACEMENT PROJECT  
883 MAIN STREET  
TORRINGTON, CT

FOR  
McCall Foundation Inc.

Revisions:	
Mark	Date

Drawing Title:  
Roof Details

Date: 06/28/2024  
Scale: 1/4"=1'-0"  
Job No.:  
CDN.

Drawing No.:  
A2

BOE STUDIO  
architects  
19 Tioga Street Torrington, CT 06790  
e-mail: boestudio1@optimum.net  
PHONE/FAX 860-489-3771